

# Gen 4 Shoebox Fixture

50W, 75W, 100W, 150W, 200W, 300W



## Specifications

<b>Lens Type</b>	Type III
<b>LED Chip</b>	Philips
<b>Efficacy</b>	140 lm/w
<b>Wattage</b>	50W - 300W
<b>Color</b>	5000K
<b>CRI</b>	>70
<b>Input Voltage</b>	100V-277V, 480V optional
<b>Power Factor</b>	>0.95
<b>Operating Temp.</b>	-40°F-122°F
<b>Dimming</b>	1-10V
<b>Rated Life</b>	> 54,000 hours
<b>Material</b>	Aluminum alloy & PC optics lens
<b>Warranty</b>	5-year warranty

## Features

- Energy-efficient and cost-effective replacement for existing parking lot lighting luminaire
- Stylish design yields less wind drag, protective cover on the back prevents bird from nesting
- Light Distribution: Type III
- Surge protection
- Photocell and motion sensor optional
- 5-pin NEMA receptacle built-in
- IP65 wet location

### Product Compliance & Certifications:

- ETL
- DLC Premium

## Description

Aleddra's 4th Generation Shoebox is an energy-efficient and cost-effective replacement for existing parking lot lighting luminaires. It is ETL certified and comes with IP65 rating. A,B,C,D,E,F type mounting accessories for choice, suitable for mounting on different size round pole, square pole and wall.

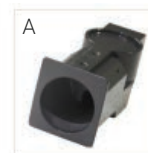

For slipfitter



For small size square pole



For small size round pole



For large size square pole



For large size round pole



For wall mounts

## Ordering Information

Product #	Wattage	Light Output
ASB-PLQ507-W050-P-B2-L1-Y(5000K)	50W	6500 lm
ASB-PLQ507-W075-P-B2-L1-Y(5000K)	75W	9000 lm
ASB-PLQ565-W100-P-B2-L2-Y(5000K)	100W	14000 lm
ASB-PLQ565-W150-P-B2-L2-Y(5000K)	150W	21000 lm
ASB-PLQ785-W200-P-B2-L2-Y(5000K)	200W	28000 lm
ASB-PLQ785-W300-P-B2-L2-Y(5000K)	300W	42000 lm

\* Y is the mounting arm: A, B2, C2, D2, E2, F2

\* Optional: Photo Cell, Motion Sensor

## Dimensions

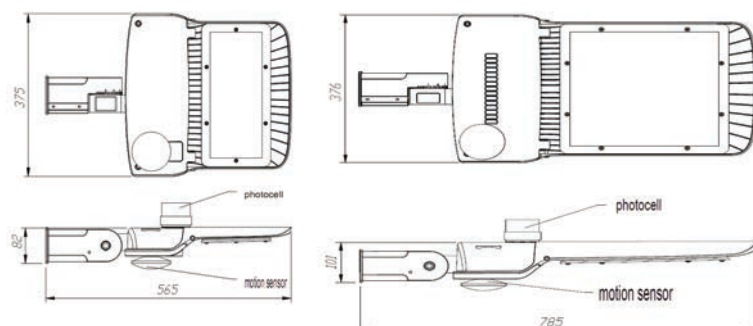

**aleddra**

425.430.4555 | info@aleddra.com | sales@aleddra.com | www.aleddra.com